

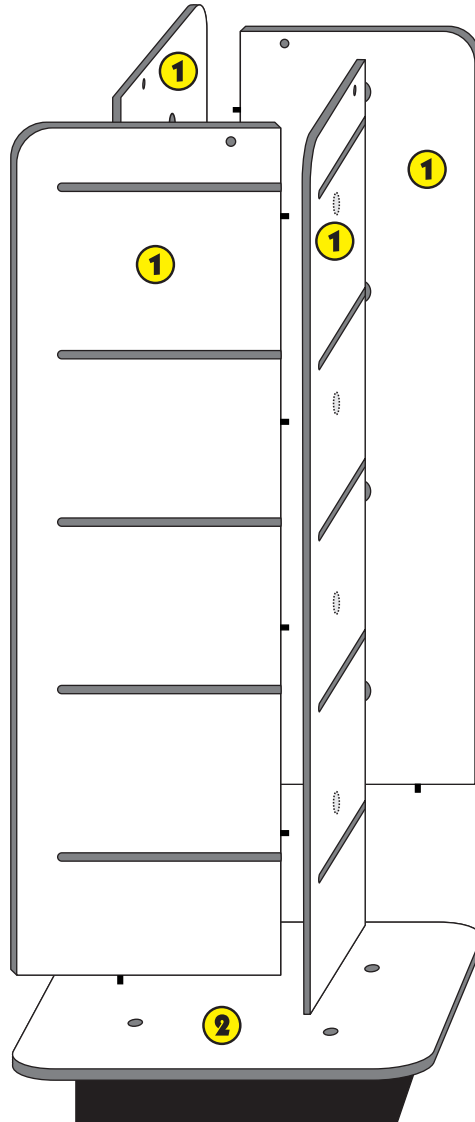

Schrock Systems RTA, Inc.

277 Lanes Bridge Road • Jesup, GA 31545
Phone (912) 427-7383 • Fax (912) 427-9602
Web - www.ssрта.com • Email - sales@ssрта.com

READY-TO-ASSEMBLE COMMERCIAL CABINET & DISPLAY SYSTEMS



1. Join four slotted side panels (1) to the backs of each adjoining panel, tightening all four fasteners on each panel with 1/4 clockwise turn (or until tight) with a Phillips screwdriver.
 2. With base/platform assembly right side up on the floor, place the assembled slotted panels onto base, aligning the four pins to the receiving fasteners on the platform. Tighten all four fasteners.
 3. See reverse side for header assembly, if applicable. Place assembled header into the hole created by the four panels on top. Secure in place with the provided push pins (x4).
- Confirm all fasteners have been tightened properly before using display. –



Schrock Systems RTA, Inc.

277 Lanes Bridge Road • Jesup, GA 31545
Phone (912) 427-7383 • Fax (912) 427-9602
Web - www.ssрта.com • Email - sales@ssрта.com

READY-TO-ASSEMBLE COMMERCIAL CABINET & DISPLAY SYSTEMS

2-Sided header assembly

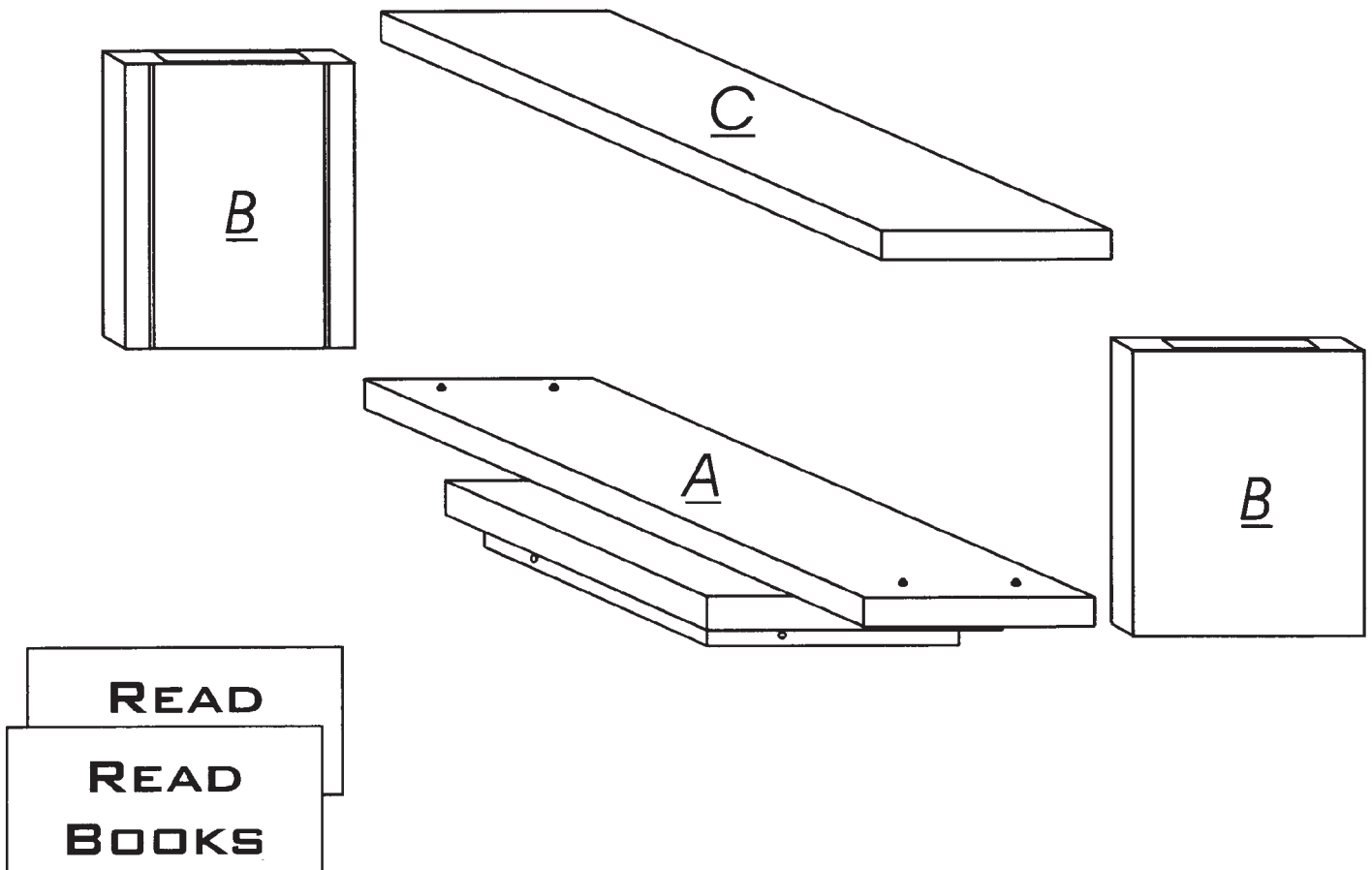

1. Place 2 uprights (B) onto base (A) screws and slide until snug, tap uprights with hammer until ends are flush.
2. Slide top plate (C) onto uprights (B) and tap top piece until flush with uprights.
3. Insert signs into slots on both sides.